



ImmSec FL

Immigration Gate

The Gunnebo ImmSec is a specifically designed double gate interlock solution used for the automated validation of travellers at one of the most security sensitive areas in an airport: immigration.

The slim and ergonomic design allows the ImmSec to be installed in single or multiple lane configurations, providing an open feel to the traveller without compromising security.

The gate automates and accelerates the immigration process whilst ensuring that only one person is permitted per authorised passage. Families and assisted travellers should be processed directly by immigration personnel

and travellers with standard cabin luggage are able to be processed automatically by the Immsec.

Designed upon a modular chassis platform to provide flexibility in accommodating different data and biometric capture and verification devices which are integrally mounted on the entry to the gate for pre-capture and validation or internally between the secure interlocked gate panels. The Immsec can be equipped with readers for smart ID cards, MRTDs and RFID passports, as well as biometric technology.

Gunnebo has employed its robust mechanism philosophy to keep operation and maintenance cost to a minimum and maximise throughput.



Technical Specifications

Drive

High reliability DC motor and brake mechanism

Materials

Casework: 304 grade grained stainless steel and anodised aluminium
 Moving panels: 10mm frameless toughened glass
 Side panels: 10mm toughened glass

Function

Uni-directional electronic passage control with single person detection and monitoring to facilitate Immigration passport verification processes.

Operational Modes

Flexibility to integrate modular mounting on end leg and inside kiosk with peripherals and biometric technology. Flexible communications protocol allowing for biometrics to control gates and mount with easy software integration.

Emergency Mode: In this mode the exit door is locked and the entry door is open.

I. One-Step Process: Designed as a one-step process combines the verification of the traveller and the traveller's secure passage through the border. This design allows the traveller to complete the whole transaction in one single process without the need to move to another stage. It usually takes the form of a mantrap e-Gate.

II. Integrated Two-Step Process: Designed as an integrated two-step process the traveller initiates the verification of the document and of the traveller's eligibility to use the system at the first stage, and then if successful moves to a second stage where a biometric match and other applicable checks are carried out. This topology is invariably implemented by using a mantrap e-Gate.

Detection levels

A. Photocells: Single person passenger movement detection in entry via beam sensing, then confirmation of passenger movement exiting. 95% detection typical. Optional left object detection.

B. Overhead detection: overhead detection inside monitoring holding area and confirming single person. 98% detection. Optional left object detection

C. Combination: C=A+B combining both technologies above, each with specific/dedicated purpose rather than overlapping. >98% detection. Photocells monitor single person detection in entry and exit whereas overhead detection monitor number of person in mantrap. Optional left object detection.

All levels include detection of: wrong way, jump over, crawl under and differing profiles caused by luggage. Left object detection is optional.

User Interface

Embedded control platform and interface with customer system via ethernet or serial connect.

BENEFITS

- Accelerates the immigration process
- Automates the entry process and collection of data
- Superior single-person detection system
- Increased security with integrated biometric technology and single-passenger detection
- Reduction in staffing costs
- Glazed passageway gives high visibility of passenger progress
- Superior Single person detection system
- Left item detection
- Disabled compliant

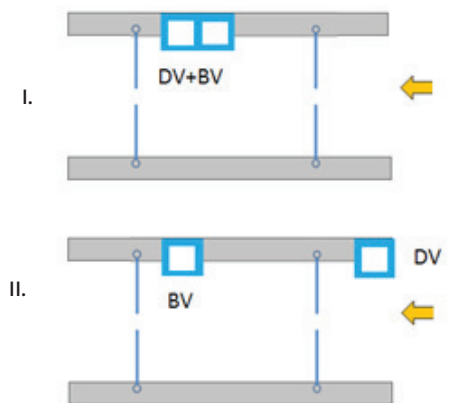

DV: Document verification
 BV: Biometric verification

FEATURES

- Up to 900mm clear walkway configurations
- Traveller status lights
- Fail safe: push-through in case of power failure
- Emergency opening configurable
- Local or remote control
- Suitable for biometric peripheral interface

TECHNICAL DATA

- Power Supply 110/230Vac 50/60Hz
- Power Rating Peak 450VA* Standby 170VA
- Operating temperature -5°C to 45°C 9% RH non-condensing
- Flow Rates Dependent on individual Immigration verification requirements
- MTTR <30 minutes
- MCBF >10 million cycles

*Approx 450VA including all third party peripherals in a typical configuration.

Site Preparation

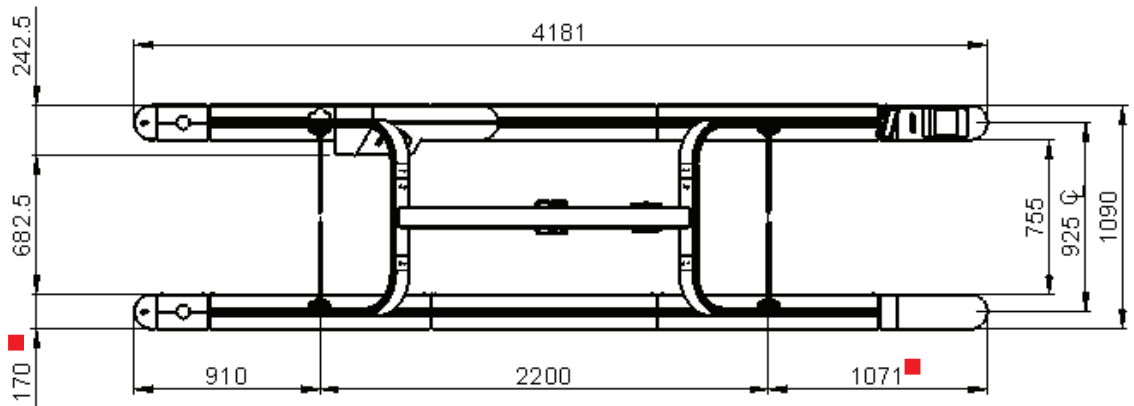
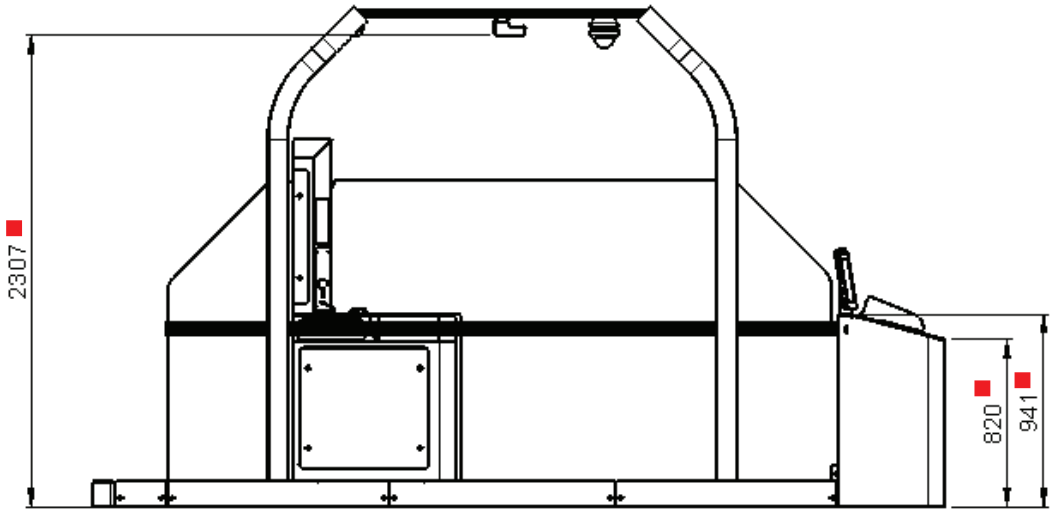

Please note: this is an example of one possible implementation. Some dimensions can vary according to requirements. Dimensions which cannot be altered have been marked with ■

Concrete Base to specification at least (cube) 300N/mm² of resistance. Base to be flat and level to +/- 5mm over footprint area.

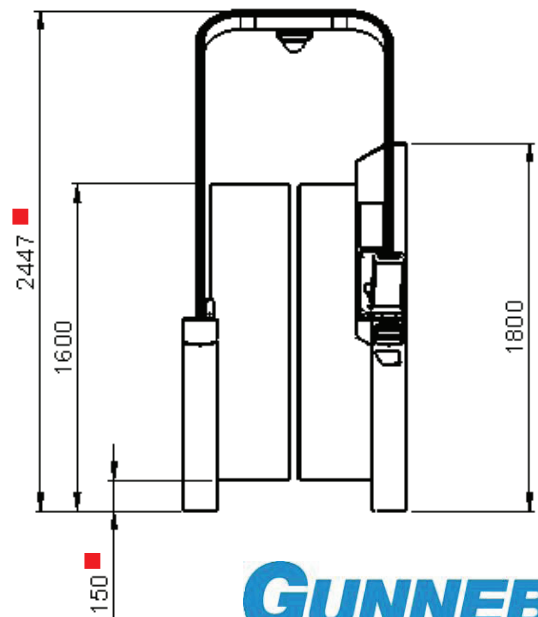

International Standards

CE compliance meeting the following directives:

- 2006/42/EC Machine Directive
- 2014/35/EU Low Voltage Directive
- 2014/30/EU EMC Directive

Norms

- EN 61000-6-3 (2007) Electromagnetic Compatibility – generic standard, emissions
- EN 61000-6-2 (2007) Electromagnetic Compatibility – generic standard, immunity
- EN60335-1 (2012) + EN60335-1/A11 (2014) Household and similar electrical appliances. Safety. General requirements
- EN16005 Power operated pedestrian doorsets – Safety in use – Requirements and test methods
- Safety system ISO EN13849 performance level C

For further information please contact:

Gunnebo Entrance Control
Bellbrook Business Park
Uckfield TN22 1QQ
United Kingdom

Tel +44 1825 761 022
E-mail info.entrancecontrol@gunnebo.com
Web www.gunnebo.com



In pursuit of its policy of continuous refinement and improvement, Gunnebo reserves the right to modify design and details given in this material at any time and without notice. Images enclosed in this material are examples of installations and may not be indicative of a standard product.